

# Sound Motions Inc.

475 Thrush Rd • PO Box 1907  
Big Bear Lake, California 92315-1907  
Voice 909-878-9104  
FAX 909-878-4248  
E-Mail: stan\_miller@mac.com

REV. 3/7/2016

## Product Information

SHOWN 1/2 ACTUAL SIZE

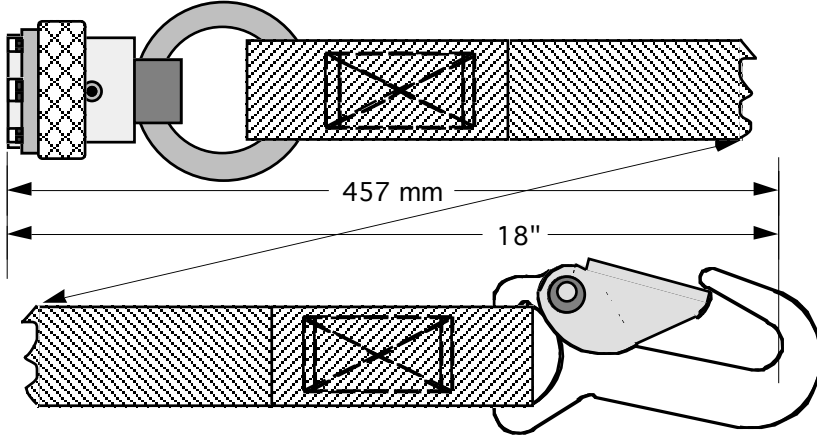

**\$68.60**

### SM-20B

The SM-20B Grabber Hook Strap is a single SM-19B Grabber Ring with a fixed web strap and large steel snap hook.

It's basic use is as a grid strap. It can be either hooked into an eye or go around a grid or pipe and be snapped back into the ring.

It is made with the all steel SM-19B 12-jaw fitting, steel snap hook and high quality 1-inch black 4500 pound test webbing and stitching. Custom made to order fixed length straps are available.

**Ship Weight**

**0.23 Kg.**

**0.5 Lbs.**

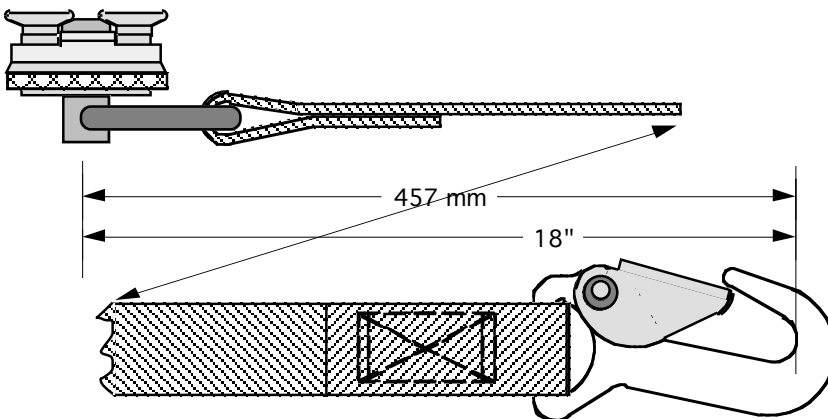

**\$72.50**

### SM-20LB

The SM-20LB "L" Track Hook Strap has a single SM-61B fitting with a fixed web strap and large steel snap hook.

It's basic use is as a grid strap. It can be either hooked into an eye or go around a grid or pipe and be snapped back into the ring.

It is made with the all steel SM-61B "L" track fitting, steel snap hook and high quality 1-inch black 4500 pound test webbing and stitching.

Custom made to order fixed length straps are available.

**Ship Weight**

**0.23 Kg.**

**0.5 Lbs.**

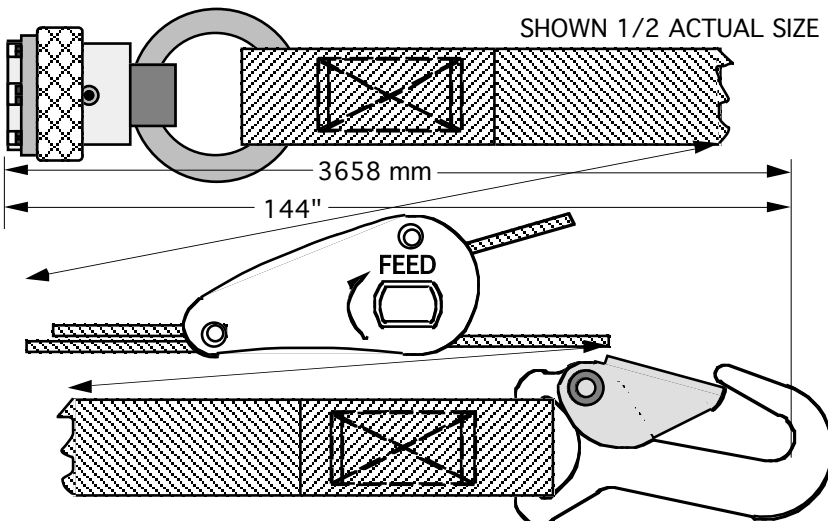

**\$52.30**

### SM-22-144

The SM-22-144 is a single SM-19B grabber/ring with an adjustable (seat belt type buckle), 1-inch black 4500 pound test webbing and stitching with a large steel snap hook.

The buckle is fixed approximately 8-inches from the grabber end. Fully extended length is 144-inches. Minimum length is approximately 13-inches.

We DO NOT RECOMMEND the use of webbed straps in permanent applications.

**Ship Weight**

**0.79 Kg.**

**1.8 Lbs.**



# Sound Motions Inc.

475 Thrush Rd • PO Box 1907  
Big Bear Lake, California 92315-1907  
Voice 909-878-9104  
FAX 909-878-4248  
E-Mail: stan\_miller@mac.com

REV. 3/7/2016

## Product Information

NOT TO SCALE

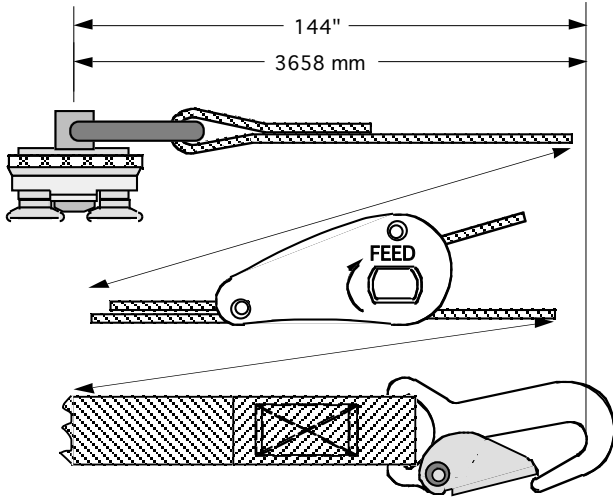

**\$79.60**

### SM-22L-144

The SM-22L-144 uses the SM-61B locking double indexing aircraft type "L" track fitting/ring plus a heavy duty snap hook separated with an adjustable (seat belt type buckle) and 1-inch black 4500 pound test webbing and stitching. The buckle is fixed approximately 8-inches from the "L" track fitting end. Fully extended length is 144-inches. Minimum length is approximately 14-inches.

We DO NOT RECOMMEND the use of webbed straps in permanent applications.

**Ship Weight**

**0.91 Kg.**

**2.0 Lbs.**

SHOWN 1/4 ACTUAL SIZE

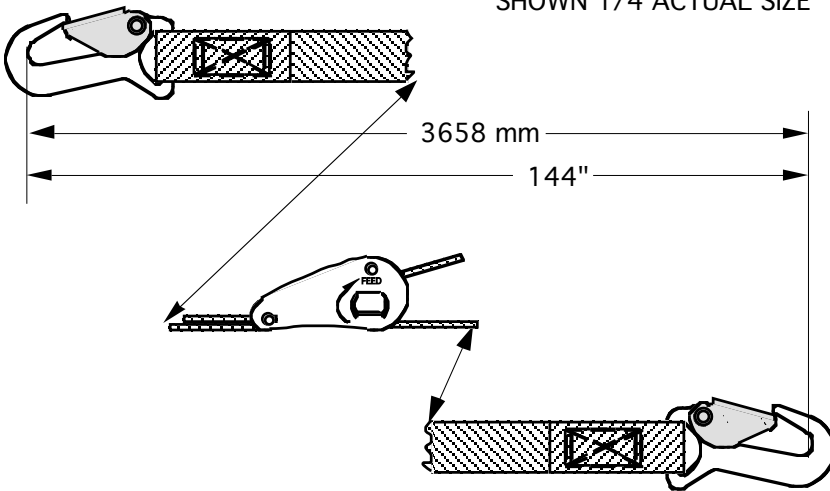

**\$22.50**

### SM-25-144

The SM-25-144 is two large steel snap hooks separated with an adjustable (seat belt type buckle) and 1-inch black 4500 pound test webbing and stitching. The buckle is fixed approximately 8-inches from one of the hook ends. Fully extended length is 144-inches. Minimum length is approximately 14-inches.

This strap is useful as an adjustment tool during installations of speaker systems. We DO NOT RECOMMEND the use of webbed straps in permanent applications, except during the installation process.

**Ship Weight**

**0.59 Kg.**

**1.3 Lbs.**

SHOWN 1/2 ACTUAL SIZE

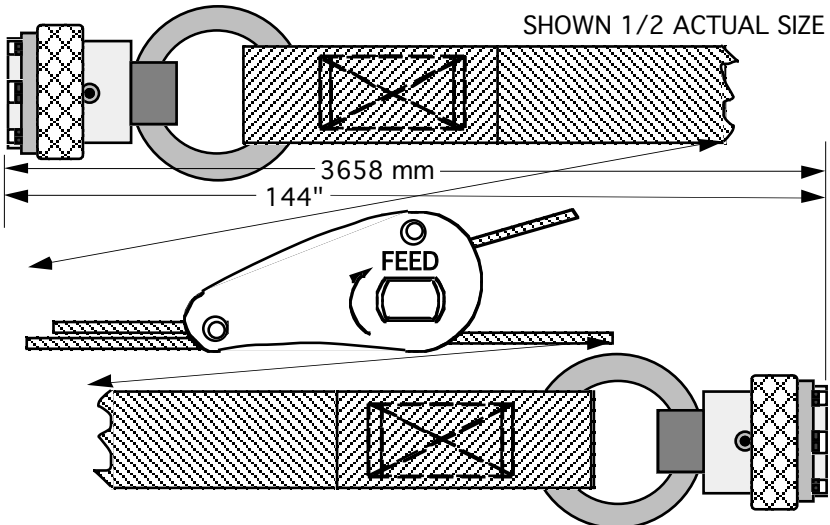

**\$84.76**

### SM-26-144

The SM-26-144 is two of the NEW all steel SM-19B locking aircraft type grabber/rings separated with an adjustable (seat belt type buckle) and 1-inch black 4500 pound test webbing and stitching. The buckle is fixed approximately 8-inches from one of the grabber ends. Fully extended length is 144-inches. Minimum length is approximately 14-inches.

We DO NOT RECOMMEND the use of webbed straps in permanent applications.

**Ship Weight**

**0.91 Kg.**

**2.0 Lbs.**

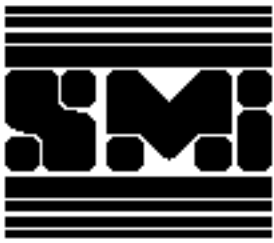

# Sound Motions Inc.

475 Thrus Rd • PO Box 1907  
 Big Bear Lake, California 92315-1907  
 Voice 909-878-9104  
 FAX 909-878-4248  
 E-Mail: stan\_miller@mac.com

REV. 3/7/2016

## Product Information

NOT TO SCALE

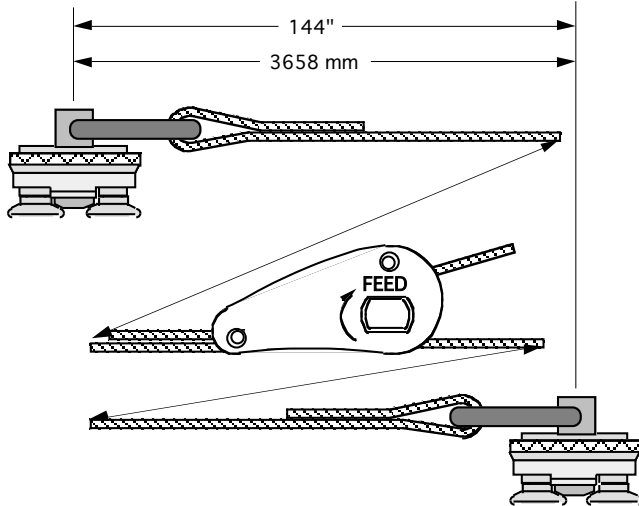

**\$119.20**

### SM-26L-144

The SM-26L-144 is two double indexing locking aircraft type "L" track fitting/rings separated with an adjustable (seat belt type buckle) and 1-inch black 4500 pound test webbing and stitching. The buckle is fixed approximately 8-inches from one of the "L" track fitting ends. Fully extended length is 144-inches. Minimum length is approximately 14-inches.

We DO NOT RECOMMEND the use of webbed straps in permanent applications.

**Ship Weight**

**1.02 Kg.**

**2.3 Lbs.**

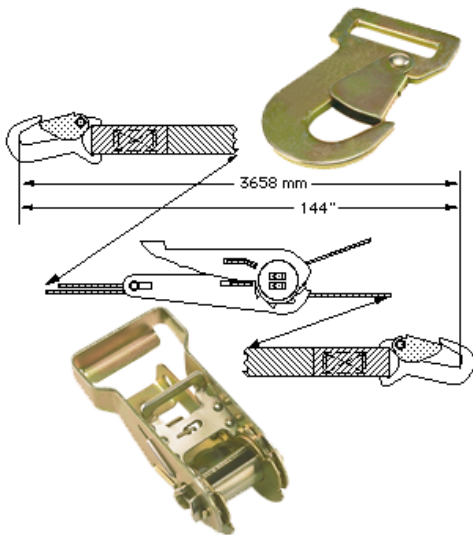

**\$32.25**

### SM-28-144

The SM-28-144 is two large steel snap hooks separated with a ratchet and 1-inch black 4500 pound test webbing and stitching. The buckle is fixed approximately 8-inches from one of the hook ends. Fully extended length is 144-inches. Minimum length is approximately 18-inches.

This strap is useful as an adjustment tool during installations of speaker systems. We DO NOT RECOMMEND the use of webbed straps in permanent applications, except during the installation process.

**THIS STRAP SHOULD NEVER BE USED AS A PRIMARY LANCING POINT**

**Ship Weight**

**0.91 Kg.**

**2.0 Lbs.**

SHOWN 1/2 ACTUAL SIZE

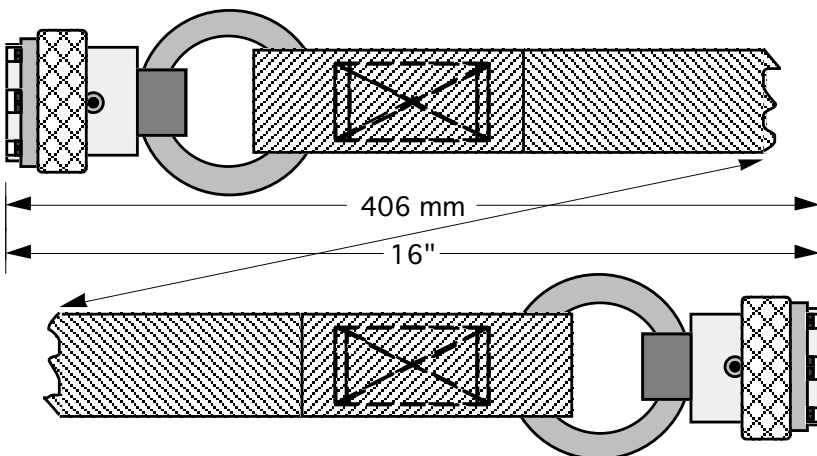

**\$69.00**

### SM-30B

The SM-30B Double Grabber Strap is manufactured using two SM-19B Grabber Rings and 1-inch black 4500 pound test webbing and stitching.

It's primary use is to "link" cabinets together for temporary applications.

We DO NOT recommend web straps for use in permanent installations.

**Ship Weight**

**0.39 Kg.**

**0.9 Lbs.**